

CEE 7/VII

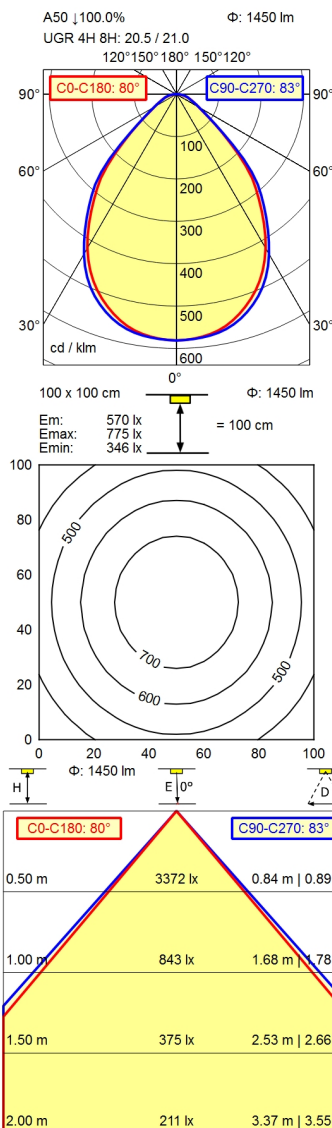

- Light source**
- Work equipment**
- Connected load**
- Power consumption**
- Luminous flux**
- Luminous efficiency**
- Light type/-color**
- Colour temperatur**
- Color rendering index**
- Light distribution**
- Direct ratio**
- Beam angle**
- Chromaticity tolerance LED**
- Glare control**
- Luminance (L65)**
- Unified glare rating (4H 8H)**
- System of protection**
- Class of protection**
- Technology**
- Operation**
- Housing**
- Light source cover**
- Weight (net)**
- Mains lead**
- Design**
- Fastening**
- Decorative contrast side parts**

- LED
- Electronic transformer
- 220 - 240 V; AC; 50 Hz; 60 Hz
- ca. 18 W
- approx. 1.450 lm
- approx. 80 lm/W
- Cold white
- approx. 4.000 K
- CRI \geq 90; R9 \geq 50
- Direct; Symmetric
- approx. 100 %
- 80°
- < 3 SDCM
- Conical prismatic screen
- \leq 5.200 cd/m²
- \leq 22
- IP 20
- I
- Switchable; -
- Rocker switch
- Aluminium/plastic; Anodised; Aluminium coloured anodised
- Structured; Plastic
- ca. 2,4 kg
- ca. 2,5 m; Mains plug: CEE 7/VII
- mounted version
- Screw down lash
- Black

Workplace-system luminaire Tameto SAHKQ 60

112989000-00551392

