

# Magnifier luminaire SNLQ 54/2

113460000-00695501

# Waldmann **W**

ENGINEERS OF LIGHT

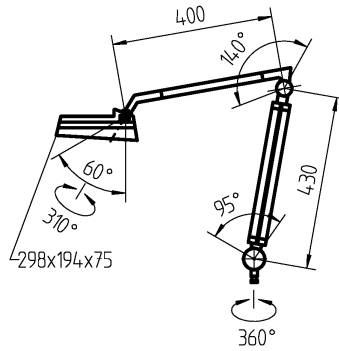

CE UK



CEE 7/VII

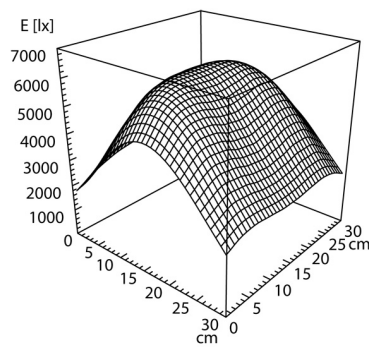
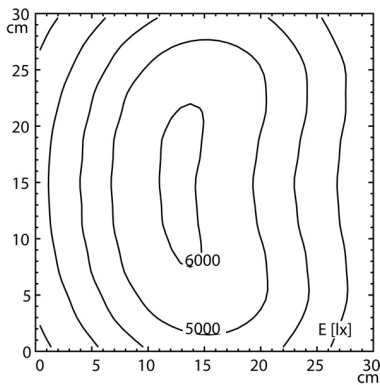

**Light source**

**Work equipment**

**Connected load**

**Power consumption**

**Light type/-color**

**Colour temperatur**

**Color rendering index**

**Light distribution**

**Direct ratio**

**System of protection**

**Class of protection**

**Technology**

**Operation**

**Housing**

**Light source cover**

**Arm**

**Weight (net)**

**Mains lead**

**Fastening**

**Lens, dimensions**

**Lens, diopters**

**Add-on lens**

LED

Electronic transformer

100 V; 120 V; 220 - 240 V; AC; 50 Hz; 60 Hz

ca. 12 W

Cold white

approx. 4.000 K

CRI ≥ 80

Direct

approx. 100 %

IP 20

I

Multi-stage switchable; -

Switch

Plastic; Pale grey

Milky; Plastic

Pale grey

ca. 4,4 kg

ca. 3 m; Mains plug; CEE 7/VII

Tap16; Table clamp (accessory); Wall bracket

(accessory); Screw-down flange

175 x 105 mm

3

Not available